

OPERATION MANUAL



COLD SAW **Model. CS-275A**

Order Code S822

Edition No : CS-275A-1

Date of Issue : 04/2021

MACHINE DETAILS

MACHINE	<input type="text" value="COLD SAW"/>
MODEL NO.	<input type="text" value="CS-275A"/>
SERIAL NO.	<input type="text"/>
DATE OF MANF.	<input type="text"/>

DISTRIBUTED BY



www.machineryhouse.com.au
www.machineryhouse.co.nz

NOTE:

This manual is only for your reference. Owing to the continuous improvement of the Hafco Metalmaster machine, changes may be made at any time without obligation or notice. Please ensure the local voltage is the same as listed on the specification plate before operating this electric machine.



NOTE:

In order to see the type and model of the machine, please see the specification plate. Usually found on the back of the machine. See example (Fig.1)

HAFCO
PRODUCT SPECIFICATION

MODEL:	<input type="text"/>
CAPACITY:	<input type="text"/>
SER. NO.:	<input type="text"/>
MFG DATE:	<input type="text"/>
WEIGHT:	<input type="text"/>
VOLTS:	<input type="text"/>
MOTOR Kw:	<input type="text"/>

www.machineryhouse.com.au
Made in China

FIG.1

CONTENTS:

1. GENERAL MACHINE INFORMATION	
1.1 Specifications.....	4
1.2 Included Accessories.....	4
1.3 Identification.....	5
2. SAFETY	
2.1 General Metalworking Machine Safety.....	6
2.2 Safe Work Procedure For Cold Saw.....	9
3. POWER SUPPLY	
3.1 Electrical Installation.....	10
3.2 Full Load Current.....	10
3.3 Controls.....	11
4. SETUP	
4.1 Unpacking.....	12
4.2 Clean Up.....	12
4.3 Site Preparation.....	12
4.4 Lifting Instructions.....	12
4.5 Anchoring To The Floor.....	13
4.6 Machine Leveling.....	13
4.7 Assembly.....	13
4.8 Test Run.....	16
5. OPERATION	
5.1 Running In The Blade.....	16
5.2 Cutting Mitre Angles.....	17
5.3 Changing The Blade.....	18
5.4 Blade Terminology.....	18
6. MAINTENANCE	
6.1 Schedule.....	20
6.2 Changing Gearbox Oil.....	21
6.3 Lubrication Oilers.....	21
6.4 Troubleshooting.....	22
Spare Parts.....	23
Risk Assessment Sheets.....	29

1.1 SPECIFICATION

Order Code	S822
MODEL	CS-275A
Cutting Head Action	Manual
Operation Type	Swivel - Dual Mitre
Round Capacity @ 90°/ 45° (mm)	75 / 65
Square Capacity @ 90°/ 45° (mm)	65 / 55
Rectangle Capacity @ 90°/ 45° (mm)	90 x 50 / 60 x 50
Blade Size (Diameter x Bore Ø (mm))	275 x 32
Vice Clamping Fixture	Manual
Coolant System Included	Yes
Table Working Height with Stand (mm)	970
Blade Speed (rpm)	45
Motor Power. (kW /hp)	1.12 /1.5
Voltage / Amperage (V / amp)	240 / 10
Shipping Dimensions (L x W x H) (mm)	940 x 560 x 720
Dimensions (L x W x H) (mm)	960 x 935 x 1573
Weight (kg)	135

1.2 ACCESSORIES INCLUDED

- Blade
- Coolant System
- Sheet Metal Stand
- Material Length Stop
- Instruction Manual

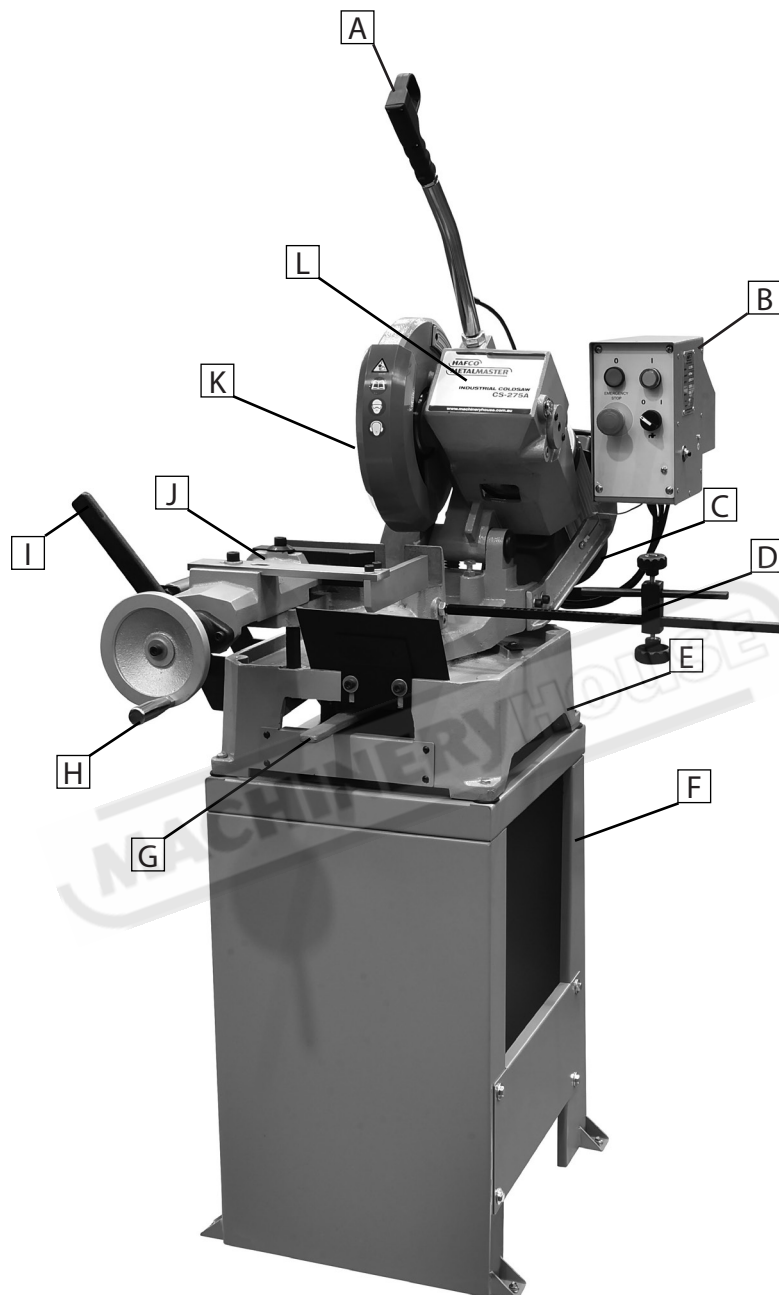
1.3 IDENTIFICATION

A	Handle With Trigger Switch	G	Swivel Lock Lever
B	Control Panel	H	Vice Handwheel
C	Motor	I	Vice Quick Action Lever
D	Length Stop	J	Vice
E	Machine Base	K	Blade Guard
F	Metal Stand	L	Cold Saw Head

2.1 GENERAL METALWORKING MACHINE SAFETY

DO NOT use this machine unless you have read this manual or have been instructed in the use of this machine in its safe use and operation



WARNING

This manual provides safety instructions on the proper setup, operation, maintenance, and service of this machine. Save this manual, refer to it often, and use it to instruct other operators. Failure to read, understand and follow the instructions in this manual may result in fire or serious personal injury—including amputation, electrocution, or death.

The owner of this machine is solely responsible for its safe use. This responsibility includes, but is not limited to proper installation in a safe environment, personnel training and authorization to use, proper inspection and maintenance, manual availability and comprehension, of the application of the safety devices, integrity, and the use of personal protective equipment.

The manufacturer will not be held liable for injury or property damage from negligence, improper training, machine modifications or misuse.



- ✓ Always wear safety glasses or goggles.
- ✓ Wear appropriate safety footwear.
- ✓ Wear respiratory protection where required.
- ✓ Gloves should never be worn while operating the machine, and only worn when handling the workpiece.
- ✓ Wear hearing protection in areas > 85 dBA. If you have trouble hearing someone speak from one metre (three feet) away, the noise level from the machine may be hazardous.
- ✓ DISCONNECTION THE MACHINE FROM POWER when making adjustments or servicing.
- ✓ Check and adjust all safety devices before each job.
- ✓ Ensure that guards are in position and in good working condition before operating.
- ✓ Ensure that all stationary equipment is anchored securely to the floor.
- ✓ Ensure all machines have a start/stop button within easy reach of the operator.
- ✓ Each machine should have only one operator at a time. However, everyone should know how to stop the machine in an emergency.

2.1 GENERAL METALWORKING MACHINE SAFETY Cont.

- ✓ Ensure that keys and adjusting wrenches have been removed from the machine before turning on the power. Appropriate storage for tooling should be provided.
- ✓ Ensure that all cutting tools and blades are clean and sharp. They should be able to cut freely without being forced.
- ✓ Stop the machine before measuring, cleaning or making any adjustments.
- ✓ Wait until the machine has stopped running to clear cuttings with a vacuum, brush or rake.
- ✓ Keep hands away from the cutting head and all moving parts.
- ✓ Avoid awkward operations and hand positions. A sudden slip could cause the hand to move into the cutting tool or blade.
- ✓ Return all portable tooling to their proper storage place after use.
- ✓ Clean all tools after use.
- ✓ Keep work area clean. Floors should be level and have a non-slip surface.
- ✓ Use good lighting so that the work piece, cutting blades, and machine controls can be seen clearly. Position any shade lighting sources so that they do not cause any glare or reflections.
- ✓ Ensure there is enough room around the machine to do the job safely.
- ✓ Obtain first aid immediately for all injuries.
- ✓ Understand that the health and fire hazards can vary from material to material. Make sure all appropriate precautions are taken.
- ✓ Clean machines and the surrounding area when the operation is finished.
- ✓ Use proper lock out procedures when servicing or cleaning the machines or power tools.

DO NOT

- × Do not distract an operator. Horseplay can lead to injuries and should be strictly prohibited.
- × Do not wear loose clothing, gloves, necktie's, rings, bracelets or other jewellery that can be come entangled in moving parts. Confine long hair.
- × Do not handle cuttings by hand because they are very sharp. Do not free a stalled cutter without turning the power off first. Do not clean hands with cutting fluids.
- × Do not use rags or wear gloves near moving parts of machines.
- × Do not use compressed air to blow debris from machines or to clean dirt from clothes.
- × Do not force the machine. It will do the job safer and better at the rate for which it was designed.



BEFORE OPERATING ANY MACHINE, TAKE TIME TO READ AND UNDERSTAND ALL SAFETY SIGNS AND SYMBOLS. IF NOT UNDERSTOOD SEEK EXPLANATION FROM YOUR SUPERVISOR.

2.1 GENERAL METALWORKING MACHINE SAFETY Cont.

HAZARDS ASSOCIATED WITH MACHINES include, but are not limited to:

- Being struck by ejected parts of the machinery
- Being struck by material ejected from the machinery
- Contact or entanglement with the machinery
- Contact or entanglement with any material in motion

Health Hazards (other than physical injury caused by moving parts)

- Chemicals hazards that can irritate, burn, or pass through the skin
- Airborne items that can be inhaled, such as oil mist, metal fumes, solvents, and dust
- Heat, noise, and vibration
- Ionizing or non-ionizing radiation (X-ray, lasers, etc.)
- Biological contamination and waste
- Soft tissue injuries (for example, to the hands, arms, shoulders, back, or neck) resulting from repetitive motion, awkward posture, extended lifting, and pressure grip)

Other Hazards

- Slips and falls from and around machinery during maintenance
- Unstable equipment that is not secured against falling over
- Safe access to/from machines (access, egress)
- Fire or explosion
- Pressure injection injuries from the release of fluids and gases under high pressure
- Electrical Hazards, such as electrocution from faulty or ungrounded electrical components
- Environment in which the machine is used (in a machine shop, or in a work site)



MACHINES ARE SAFEGUARDED TO PROTECT THE OPERATOR FROM INJURY OR DEATH WITH THE PLACEMENT OF GUARDS. MACHINES MUST NOT BE OPERATED WITH THE GUARDS REMOVED OR DAMAGED.

2.2 SAFE WORK PROCEDURE FOR COLD SAW

DO NOT use this machine unless you have been instructed in its safe use and operation and have read and understood this manual



Safety glasses must be worn at all times in work areas



Long and loose hair must be contained.



Hearing protection must be worn



Sturdy footwear must be worn at all times in work areas



Close fitting/protective clothing must be worn



Rings and jewellery must not be worn.

PRE-OPERATIONAL SAFETY CHECKS

- ✓ Locate and ensure you are familiar with all machine operations and controls.
- ✓ Ensure all guards are fitted, secure and functional. Do not operate if guards are missing or faulty.
- ✓ Check workspaces and walkways to ensure no slip/trip hazards are present.
- ✓ Ensure saw blade is in good condition.
- ✓ Check the operation of the work vice.
- ✓ Check coolant delivery system to allow for sufficient flow of coolant.

OPERATIONAL SAFETY CHECKS

- ✓ Ensure the workpiece is securely held in the work vice.
- ✓ Support overhanging work. Signpost if it presents a hazard.
- ✓ Listen for any unusual noises during the sawing process.

AFTER OPERATION

- ✓ Switch off the machine when work completed.
- ✓ Before making adjustments or before cleaning swarf accumulations, switch off and bring the machine to a complete standstill.
- ✓ Clean up and absorb any coolant spills immediately.
- ✓ Leave the machine in a safe, clean and tidy state.

DO NOT

- ✗ Do not use faulty equipment. Immediately report suspect equipment.
- ✗ Do not cut very small items.
- ✗ Do not cut materials other than metal.
- ✗ Never leave the machine running unattended.
- ✗ Never force the saw into the workpiece. Use a slow and even feed rate.

POTENTIAL HAZARDS AND INJURIES

- Possible skin irritation from coolants.
- Eye injuries.
- Sharp edges and burrs, metal splinters.
- Noise.

3. POWER SUPPLY

3.1 ELECTRICAL INSTALLATION

Place the machine near an existing power source. Make sure all power cords are protected from traffic, material handling, moisture, chemicals, or other hazards. Make sure there is access to a means of disconnecting the power source. The electrical circuit must meet the requirements for 240V.

NOTE: The use of an extension cord is not recommended as it may decrease the life of electrical components on your machine.

ELECTRICAL REQUIREMENTS

Nominal Voltage.....	240V
Cycle.....	50 Hz
Phase.....	Single Phase
Power Supply Circuit.....	10 Amps
Full Load Current.....	5.1 Amps

(Full load current rating is also on the specification plate on the motor.)

3.2 FULL-LOAD CURRENT RATING

The full-load current rating is the amperage a machine draws when running at 100% of the output power. Where machines have more than one motor, the full load current is the amperage drawn by the largest motor or a total of all the motors and electrical devices that might operate at one time during normal operations.

Full-Load Current Rating for these machine at 240V is 5.1 Amps

It should be noted that the full-load current is not the maximum amount of amps that the machine will draw. If the machine is overloaded, it will draw additional amps beyond the full-load rating and if the machine is overloaded for a long period of time, damage, overheating, or fire may be caused to the motor and circuitry.

This is especially true if connected to an undersized circuit or a long extension lead. To reduce the risk of these hazards, avoid overloading the machine during operation and make sure it is connected to a power supply circuit that meets the requirements.



3.3 CONTROLS

The purpose of this control overview is to provide the novice machine operator with a basic understanding of how the machine is used during operation, and the machine controls and what they do. It also helps the operator to understand if they are discussed later in this manual.

NOTE: Do not start the machine until all of the setup instructions have been performed. Operating a machine that is not set up may result in malfunctions or unexpected results that may lead to injury, death or machine/property damage.

- A. **Stop Button:** When pressed stops the supply of power to the machine. (Fig. 3.1)
- B. **Start Button:** Supplies power to machine for operation.
- C. **Emergency Stop Button:** Cuts power to motor and remains depressed until reset. Twist clockwise to reset. (Fig. 3.1)
- D. **Coolant Pump Switch:** Switches ON and OFF the power supply to the coolant pump. (Fig. 3.1)

NOTE: The coolant pump will not operate until the trigger switch is pressed.

- E. **Trigger Switch:** Turns the motor ON, rotating the blade and also activating the coolant pump. (Fig. 3.2)
- F. **Vice Handle:** Opens and closes the vise jaws to clamp the workpiece. (Fig. 3.3)
- G. **Quick Action Handle:** Allows for a small amount of opening and closing for quick operation. (Fig. 3.3)
- H. **Coolant Tap:** Adjusts the coolant flow

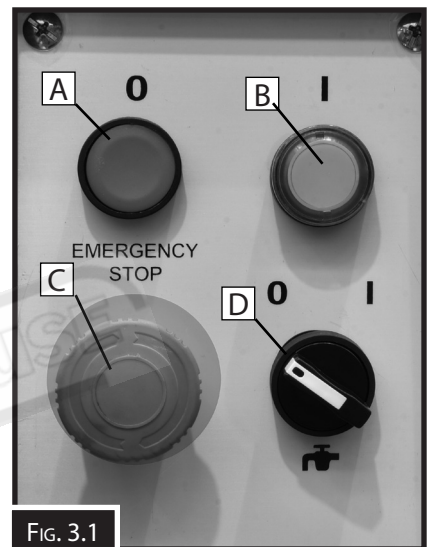

FIG. 3.1

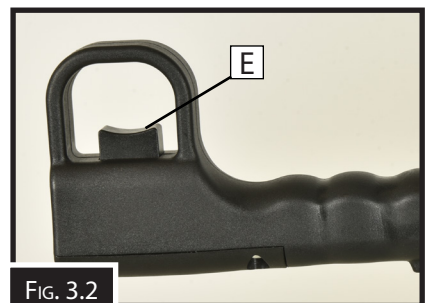

FIG. 3.2

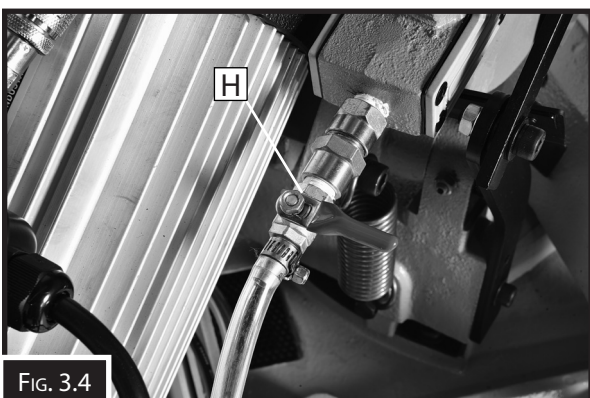

FIG. 3.4

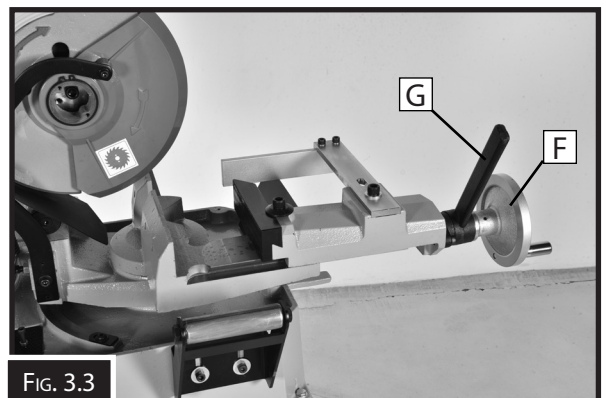

FIG. 3.3

4 SETUP

4.1 UNPACKING

This machine was carefully packaged for safe transport. When unpacking, separate all enclosed items from packaging materials and inspect them for shipping damage. If items are damaged, please contact your distributor.

NOTE: *Save all the packaging materials until you are completely satisfied with the machine and have resolved any issues with the distributor, or the shipping agent.*

When unpacking, check the packing list to make sure that all parts shown are included. If any parts are missing or broken, please contact the your distributor.

4.2 CLEAN - UP

The unpainted surfaces of the machine have been coated with a waxy oil to protect them from corrosion during shipment. Remove the protective coating with a solvent cleaner or a citrus based degreaser.

Optimum performance from your machine will be achieved when you clean all moving parts or sliding contact surfaces that are coated with rust prevented products.

It is advised to avoid chlorine based solvents, such as acetone or brake parts cleaner, as they will damage painted surfaces and strip metal should they come in contact. Always follow the manufacturer's instructions when using any type of cleaning product.

4.3 SITE PREPARATION

When selecting the site for the machine, consider the largest size of workpiece that will be processed through the machine and provide enough space around the machine for operating the machine safely. Consideration should be given to the installation of auxiliary equipment. Leave enough space around the machine to open or remove doors/covers as required for the maintenance and service as described in this manual.

It is recommended that the machine is anchored to the floor to prevent tipping or shifting. It also reduces vibration that may occur during operation.

4.4 LIFTING INSTRUCTIONS

On the day that the machine arrives, make sure that a crane or forklift with sufficient capacity is available to unload the machine from the vehicle. Ensure access to the chosen site is clear and that doors and ceilings are sufficiently high and wide enough to receive the machine. To handle the machine, the slings should be positioned so the machine is level when lifted. When using slings please take note of the sling angle and the loads that apply.

Prepare the machine for lifting by carefully placing the sling around the collar of the movable jaw and the motor mount.

NOTE: *Only use certified slings*



FIG. 4.1

4.5 ANCHORING TO THE FLOOR

The machine is best mounted on a concrete slab. Masonry anchors with bolts are the best way to anchor machinery, because the anchors sit flush with the floor surface, making it easy to unbolt and move the machine later, if needed. (Fig. 4.2)

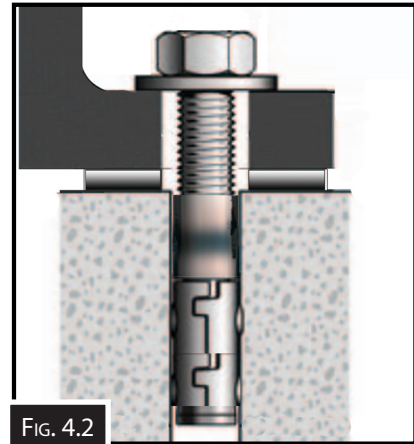

FIG. 4.2

4.6 MACHINE LEVELING

To set your machine up so that it operates to optimum performance, apply the following procedure. After your machine has been anchored to a concrete slab floor, it then needs to be leveled. Loosen the hold down bolts and place a level on the surface of the working table. Metal shims need to be placed under corner of the base of the machine until level. Once level then tighten the hold down bolts. (Fig. 4.3).

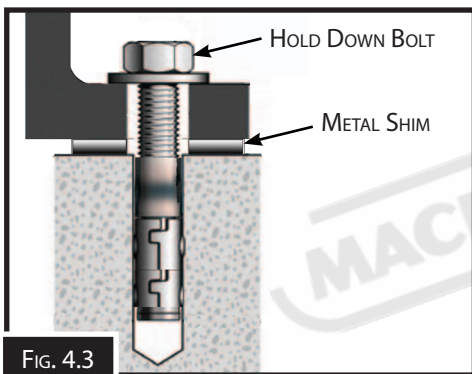

FIG. 4.3



The machine must not rest on supports other than those defined in Fig. 4.3

4.7 ASSEMBLY

The machine must be fully assembled before it can be operated. First clean any parts that are coated in rust preventative to ensure the assembly process can proceed smoothly.

Attach The Machine to the stand.

Use an overhead lifting device to lift the machine. Put the 4 pieces of round rubber between the machine and the stand. Align the bolt holes on the four corners of the machine to the corresponding holes on the stand and the holes in the rubber inserts, then lower the machine onto the stand. (Fig.4.4)

Secure the machine onto the stand using the 4 x M8x35 screws and M8 spring washers .

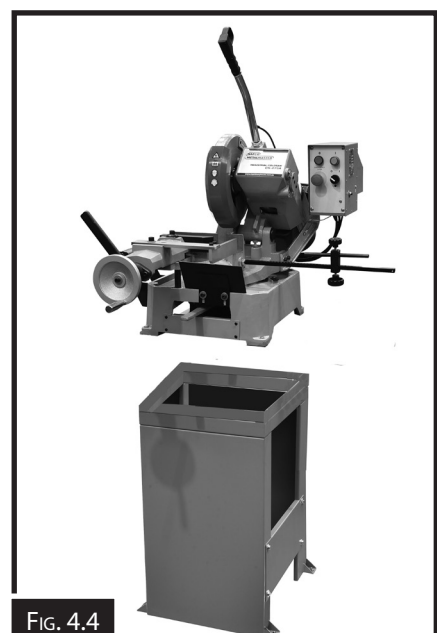
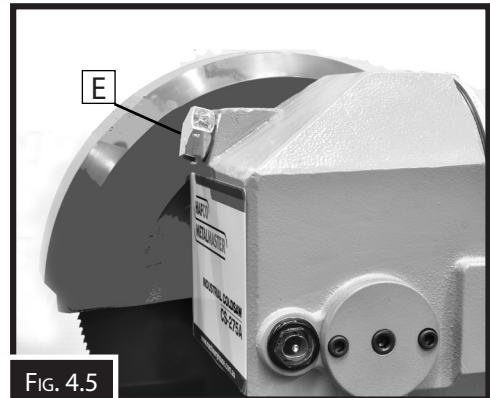

FIG. 4.4

4.7 ASSEMBLY CONT.

Remove the oil fill transport plug from gear transfer case. Use a wrench to unscrew a M20 X 40 hex head screw (E) from the oil fill hole (Fig. 4.5).



Insert the threaded end of the control handle into the gear oil fill hole (E in Fig.4.5).

Turn the control handle (G) along the shaft to screw in the control handle (G) until a tight fit.

Align the handle (G) so that the trigger switch (K) points up.

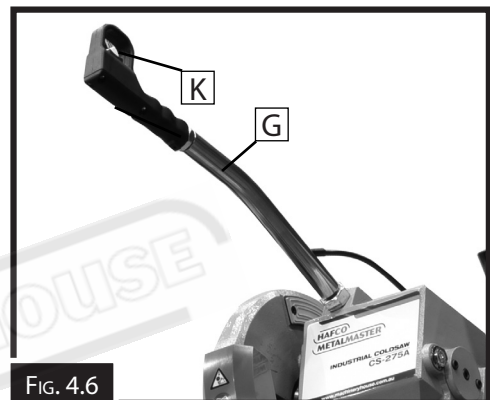

Connect the control handle cable .

Locate the open socket (F) at the side of the electrical box on the top of the motor.

Plug in the control handle cable into the open socket. Tighten the knurled section of the screw on the cable connector nut.

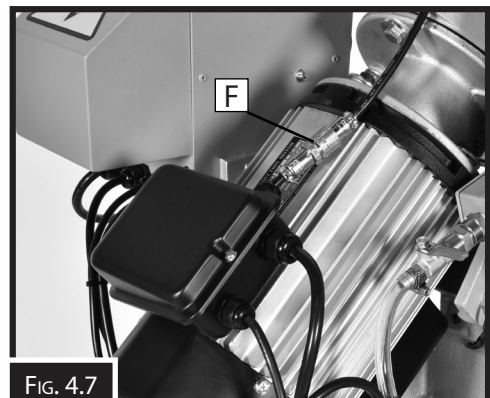

Attach the support roller on the L/H side of the machine. Place the support roller (H) next to the machine base.

Align the 2 slots (I) in the base of the support roller with the matching screw holes on the base of the machine.

Place a M10 washer on each of the two M10x25 hex head bolts and loosely screw the hex head bolts into the aligned slot (I) and holes. (Fig. 4.8)

Adjust the height of the support roller (H) by placing a level across the mouth of the vise and support roller. If a long level is not available, use a straight edge. Raise or lower the support roller until level.

Secure the support roller (H) in place by tightening the two hex head bolts.

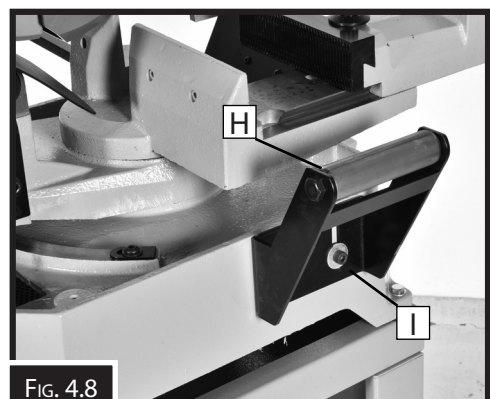

4.7 ASSEMBLY CONT.

Attach the length stop.
Insert the thread end of the long rod (J) into the side of the vise.
Turn the long rod clockwise until snug.
Use a wrench to turn the M12 hex nut on the long rod (J) counter-clockwise, until the length stop unit is secure.

Install the coolant system.
The drawer-like coolant system is built into the rear of the base and has a capacity of 2 Litres
The coolant wire with plug and a hose have already been installed on the machine.
Loosen the 4 screws on both sides of the base at the rear. (Fig. 4.9)

Using the handle pull the coolant drawer out half way as shown (Fig. 4.10)
Fill the coolant tank 2/3 full (approx. 2L) with XDP-1800 soluble oil (Order Code S090) at a mixture of 20:1. Once coolant is filled, push the tank back into position and fit the 4 screws back making sure the tank is secured.

Installing the splash plates
Insert a splash plate onto the front wall of the machine base. Align the 2 slots in the base of the splash plate with the matching screw holes on the machine base.
Apply a washer to each of the 2 socket head cap screws M8x20mm.(Fig. 4.11)
Loosely screw the socket hex head screws into the aligned slot and holes.
Adjust the splash plate to the proper position and tighten the screws.

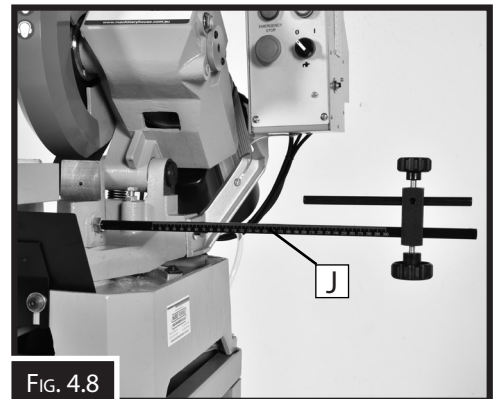

FIG. 4.8

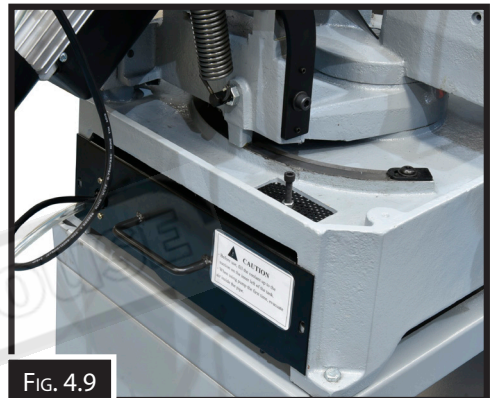

FIG. 4.9

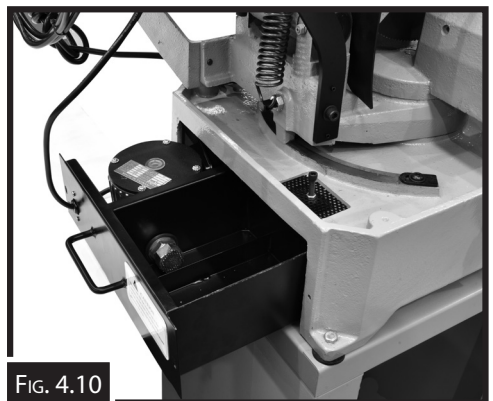

FIG. 4.10

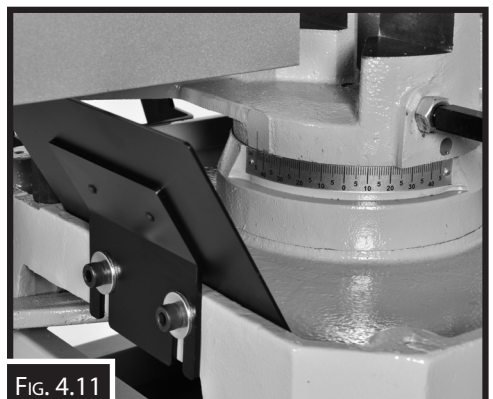

FIG. 4.11

4.8 TEST RUN

Once assembly is complete, the machine needs to have a test run to ensure it is properly connected to the power and safety components are functioning correctly.

If you find an unusual problem during the test run, immediately stop the machine, disconnect it from the power, and fix the problem BEFORE operating the machine again. The Troubleshooting table in the Maintenance section also may be able to help the operator.

To test run machine:

1. Clear all setup tools away from machine.
2. Verify gearbox is filled with oil
3. Press Emergency Stop button.
4. Connect machine to power source.
5. Press the power switch to "1" (ON) position (B in Fig. 3.1).
6. Rotate Emergency Stop button (C in Fig. 3.1) clockwise to reset
7. Turn cutting fluid valve to open position (H in Fig. 3.4).
8. Press the trigger button on the control lever arm. Cutting fluid should begin flowing onto blade.
9. Motor should run smoothly and without unusual problems or noises.
Address strange or unusual noises by referring to Troubleshooting on Page 22 for help.
Always disconnect machine from power when investigating or correcting potential problems.
10. Turn the machine OFF by pressing the emergency stop button.
11. Press the trigger button. The saw should not run. If the saw does start, immediately disconnect the power to the saw. The Emergency Stop button is not working correctly
The safety feature must work properly before proceeding with regular operations.
Contact your local dealer for Technical Support or service.

5. OPERATION

This machine may perform many types of operations that are beyond the scope of this manual. Many of these operations may be dangerous or deadly if performed incorrectly.

The instructions in this section are written with the understanding that the operator has the necessary knowledge and skills to operate this machine. If at any time you are experiencing difficulties performing any operation, stop using the machine!

If you are an inexperienced operator, we strongly recommend that you read books, trade articles, or seek training from an experienced operator before performing any unfamiliar operations. **Above all, your safety should come first!**

5.1 RUNNING IN THE BLADE

When cutting for the first time, it is good practice to run in the blade. During the break-in period, only mild pressure should be exerted on the blade (about half of the normal feed pressure for a properly broken-in blade). Plenty of coolant should be applied during this period.

5.2 CUTTING MITRE ANGLES

The head rotates 45° left or right of center for precise angled cuts. The miter scale shows the angle of the blade, and the miter lock lever secures the angle for repeated cuts. Ensure the saw is properly mounted to the floor before using the machine, as the saw base can shift with larger workpieces.

To set a Miter Angle:

1. DISCONNECT THE MACHINE FROM THE POWER!
2. Move the mitre lock lever to the right to release the headstock. (Fig. 5.2)
3. Rotate the saw headstock to the desired angle using miter scale as a guide. Once desired angle is reached, move the miter lock lever left to secure the setting.
4. Ensure the blade clearance by lowering the head. If necessary, adjust the vise jaw to provide adequate clearance,
5. To adjust the vise jaw, loosen the vise jaw cap screw until the vise jaw slides freely. Position the vise jaw approximately 12mm away from the blade (Fig. 5.3)

Note: At certain angle settings, it may not be possible to set jaw within 12mm of the workpiece. If this is the case, adjust jaw as far as it can go while still being securely clamped. (Fig. 5.4)

6. Adjust the vice jaw outrigger to support the cut off piece. In some cases the outrigger may need to be moved to the other slotted hole. (Fig. 5.5)
5. Return the saw to the upright position.

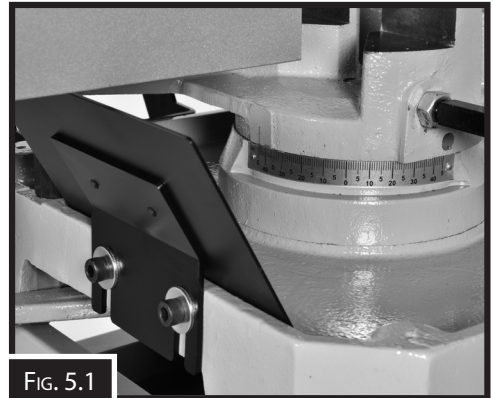

FIG. 5.1

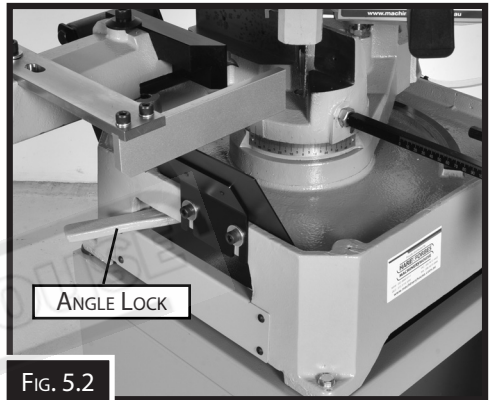

FIG. 5.2

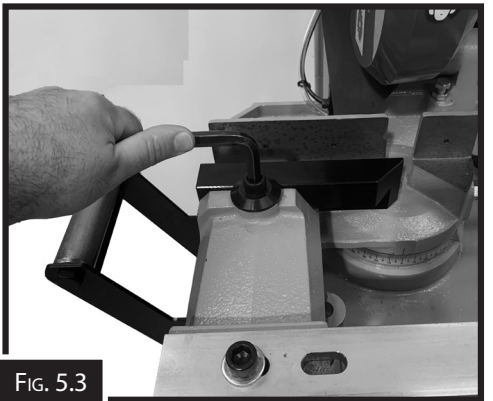

FIG. 5.3

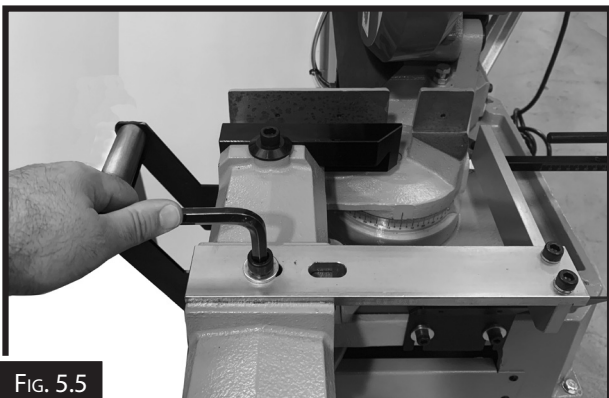

FIG. 5.5

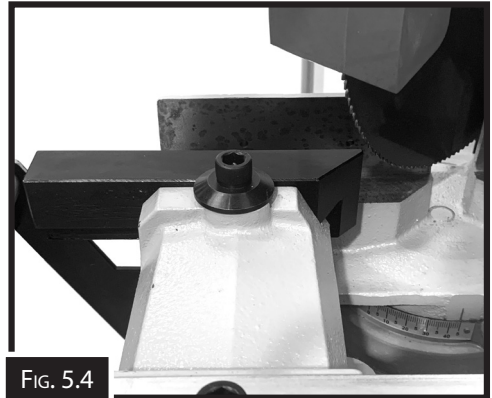

FIG. 5.4

5.3 CHANGING THE BLADE.

Metal cutting blades should be checked regularly for wear or damage to ensure a high-quality workpiece finish and to determine if replacement is necessary.

To replace the blade:

1. DISCONNECT THE SAW FROM THE POWER!
2. Disconnect the blade guard linkage by removing the cap screw connecting linkage to the guard. (Fig. 5.6).
3. Rotate the safety moving guard back.
4. Remove the arbor cap screw (Fig. 5.7). It features a left-hand thread and loosens when turned clockwise.
5. Remove the blade and blade flange.
6. Align and place the blade flange on the new blade,
7. Align the flange pins with the holes in the saw arbor, and install the blade, using a hex wrench.
8. Lower the blade guard, and reconnect blade guard linkage with the cap screw removed

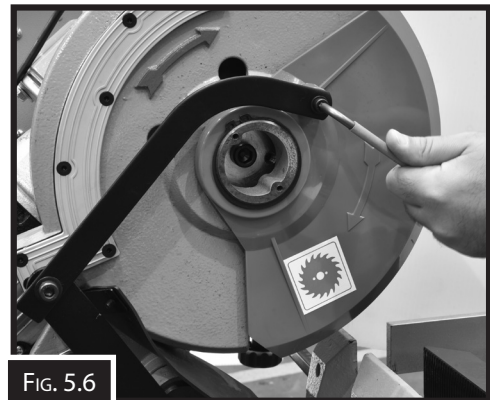

FIG. 5.6



FIG. 5.7

5.4 BLADE TERMINOLOGY

- A. Pitch:** The distance from the tip of one tooth to the tip of the next. Known as in Teeth/Inch
- B. Gullet:** The shallow area between the tips of the teeth.
- C. Front Rake Angle:** The measurement of the angle between the tip of the blade tooth and a line tangent to the perimeter of the blade.
- D. Rear Rake Angle:** The measurement of the angle formed between the face of the tooth and the diameter of the blade.
- E. Tooth Depth:** The distance from the tip of the tooth to the bottom of the adjacent gullet.
- F. Cut Width:** The width of the cut
- G. Blade Size:** The diameter of the blade

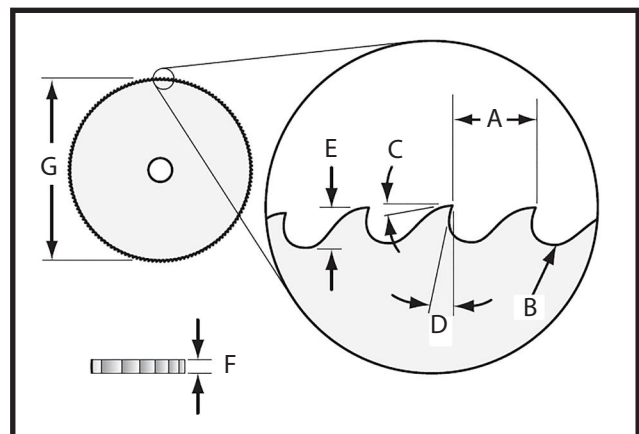

5.4 BLADE TERMINOLOGY CONT.

Blade Structure

The most commonly used blades are made of extra high speed steel (HHS/Mo5+Co5) with a treated tooth.

Choosing the Saw Blade

Choose a tooth pitch that is suitable for the workpiece. Thin walled or variable section work pieces such as profiles, pipes, and plates requires a small tooth pitch, so that at least 3~6 teeth are in contact with the material while cutting.

Large solid sections requires a large tooth pitch, to allow for greater volume of the shavings. Soft materials or plastics such as light alloys, mild bronze, Teflon, wood, etc., requires a large pitch teeth to avoid clogging.





Pitch

The most important consideration when selecting a blade is the pitch of the blade. This is measured in "teeth per inch" (TPI). Proper TPI for any cut depends on the cross-section size and wall thickness of the workpiece. If the blade pitch is too coarse for the cut, there will be too few teeth making the cut at any given time. This results in broken blade teeth and rough cuts due to excessive strain applied to both the blade and the workpiece. Use a blade pitch that keeps at least three teeth in the workpiece at any time.

If the blade pitch is too fine for the cut, teeth will remain in the workpiece and remove more material than the blade gullet can hold. This buildup of chips prevents the teeth from cutting effectively and results in poor cutting efficiency, overheating, and rapidly rounded-off teeth

Speed and Feed Rate.

The Hafco Metal master CS-275A Cold Saw has only one speed (45 rpm) which was chosen as it is the correct speed for a 275mm blade, but the feed rate is controlled only by the feel of the operator. As there is no mechanical indication of the feed rate the feed rate can only be judged by the chip configuration.

CHIP COLOUR	CHIP DESCRIPTION	FEED RATE	CHIP SHAPE	ACTION REQUIRED
SILVER	SMALL CHIPS	NEEDS TO INCREASE		
SILVER	THIN STRAIGHT CHIPS	NEEDS TO INCREASE		
SILVER	THIN TIGHT CURLS	NEEDS TO DECREASE		BLADE PITCH MAY BE WRONG
BLUE/BROWN	THICK SHORT CHIPS	NEEDS TO DECREASE		
SILVER	THIN CURLED CHIPS	CORRECT		

6. MAINTENANCE



WARNING

Before maintaining or cleaning the machine, turn off the circuit breaker, or disconnect the machine from the power supply.

Post a sign to inform other workers that the machine is under maintenance.

For optimum performance from the machine, it is important that the machine is well cleaned and maintain. Follow the maintenance schedule listed in the following section and refer to any specific instructions given.

6.1 SCHEDULE

Daily Maintenance

- Check for any loose mounting bolts/screws/nuts.
- Check for damaged or worn saw blade.
- Check the coolant level.
- Check that there is proper function of blade guard.
- General cleanup to prevent buildup of metal particulate.

Weekly Maintenance

- Clean machine thoroughly, including coolant tank to remove particulate.
- Clean coolant screens on machine base and fluid reservoir.
- Check/adjust gearbox oil level (see Page 21).
- Lubricate vise leadscrew

Monthly Check:

- Check/tighten machine bolts.
- Oil saw hinge pin ball oiler.
- Lubricate base pivot (see Page 21).

Every Six Months:

- Change gearbox oil (see Page 21).

6.2 CHANGING GEARBOX OIL

Change the oil in the reduction unit using oil type BROBOLUBE Industrial Gearbox Oil (Order Code S092) or equivalent oil. Follow the procedure below.

To add/change gearbox oil:

1. DISCONNECT THE SAW FROM THE POWER SUPPLY!
2. Raise the saw to up most position, and remove the operating handle to access the oil fill hole. This will also allow the oil to drain more freely.
3. Place an oil drain pan beneath the saw gearbox, and remove the oil drain plug, located on the bottom side of the gearbox (Fig. 6.1).
4. Hold the drain pan under the drain plug, then tilt the gearbox forward, allowing oil to drain out.
5. Have an assistant hold the headstock in place, and replace the drain plug.
6. Insert a funnel into the fill hole. Add BROBOLUBE or equivalent oil until the oil level is at the halfway mark in the sight glass. Allow time for the oil to settle in the sight glass before taking a reading.
7. Wipe away any excess oil and re-install the operating handle.

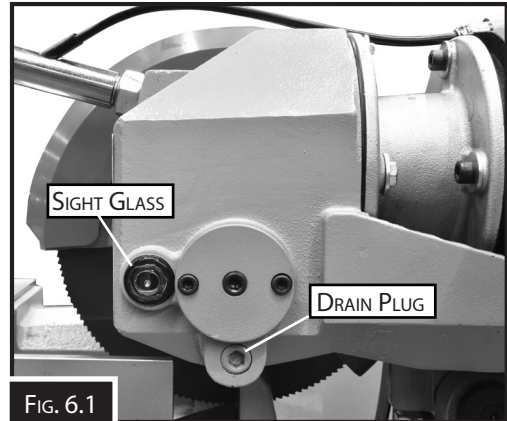

6.3 LUBRICATION OILERS

This cold cut saw requires regular lubrication to maintain smooth movement and ensure long-lasting operation.

Proper lubrication of the hinge-pin ball oiler, is done with a pump-type oil can that has a tip wide enough to seal the ball oil inlet. It is not recommended to use a metal needle or lance-type tips, as they can push the ball too far into the oiler, break the spring seat, and lodge the ball in the oil galley. (Fig. 6.2)

If you see sludge and dirt coming out of the lubrication area, continue pumping the oil can until the oil runs clear, and wipe away any excess oil.

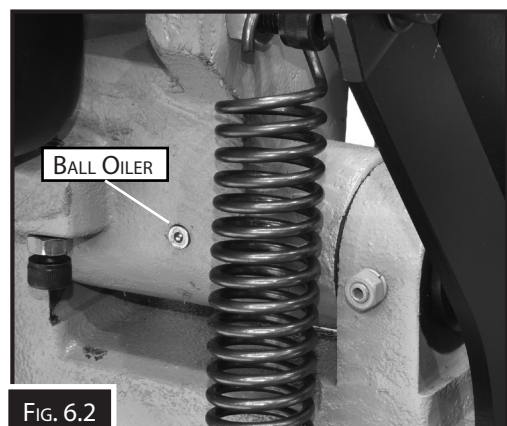

6.4 TROUBLESHOOTING

Review the troubleshooting and procedures in this section if a problem develops with your machine. If you need replacement parts then follow the procedure in beginning of the spare parts section or if additional help with a procedure is required, then contact your distributor.

Note: Make sure you have the model of the machine, serial number, and manufacture date before calling.

Symptoms	Possible Cause	Possible Solution
Machine does not start	<ol style="list-style-type: none"> Emergency stop button depressed/at fault. Plug/receptacle at fault/wired wrong. Incorrect power supply voltage or circuit size. Power supply circuit breaker tripped or fuse blown. Wiring open/has high resistance. Capacitor at fault. Master power switch at fault. Motor at fault 	<ol style="list-style-type: none"> Rotate button head to reset. Replace. Test for good contacts; correct the wiring. Ensure correct power supply voltage and circuit size. Ensure circuit is sized correctly and free of shorts. Reset breaker or replace fuse. Check/fix broken, disconnected, or corroded wires. Test; check/fix broken wiring; replace capacitor. Test/replace switch. Test/repair/replace.
Machine stalls or is under-power	<ol style="list-style-type: none"> Workpiece crooked; vise jaws are loose or incorrectly adjusted. Machine undersized for task. Wrong workpiece material. Dull blade. Plug/receptacle at fault. Motor wired incorrectly. Motor overheated. Contactors not energized. Motor bearings at fault. Gearbox at fault. 	<ol style="list-style-type: none"> Straighten or replace workpiece/adjust vise jaws to avoid workpiece binding saw blade. Use correct blade; reduce feed rate, use more coolant if possible. Use correct type/size of metal for cutting operation. Sharpen/replace blade. Test for good contacts/correct wiring. Wire motor correctly. Clean motor, let cool, and reduce workload. Test all legs of contactor; repair/replace. Test/repair/replace. Replace broken or slipping gears.
Machine has vibration or noisy operation.	<ol style="list-style-type: none"> Workpiece loose. Machine incorrectly mounted to floor. Motor or component loose. Motor fan rubbing on fan cover. Motor bearings at fault. Gearbox at fault. 	<ol style="list-style-type: none"> Use correct vise locations and re-clip workpiece. Tighten mounting bolts; relocate/shim machine. Inspect/replace damaged bolts/nuts, and re-tighten with thread locking fluid. Fix/replace fan cover; replace loose/damaged fan. Test by rotating shaft; rotational grinding/loose shaft requires bearing replacement. Replace broken or slipping gears.
Premature blade wear.	<ol style="list-style-type: none"> Cutting pressure too high. Cutting pressure too low. Incorrect blade for material type. Inadequate blade lubrication 	<ol style="list-style-type: none"> Reduce cutting pressure. Increase cutting pressure. Choose correct blade for material type. Check level of cutting fluid, valve position, fluid screens, functionality of pump, and flow of hose.
Teeth breaking or chipping.	<ol style="list-style-type: none"> Material type too hard, incorrectly shaped, or has flaws. Wrong tooth pitch/profile. Workpiece not secured in vise. Vibrations in machine causing blade to "bounce" on workpiece. Cutting pressure too high. Teeth touching workpiece before cut starts Inadequate blade lubrication. 	<ol style="list-style-type: none"> Decrease cutting pressure, ensure workpiece does not contain flaws. Choose correct blade for material type. Check vice, jaws, and clamping pressure. Find/correct source of machine vibration. Reduce cutting pressure. Do not allow blade teeth to touch workpiece during start-up. Check level of cutting fluid, valve position, functionality of pump, and flow of hose.

SPARE PARTS SECTION

COLD SAW

Model. CS-275A

Order Code S822

Edition No : CS-275A-1

Date of Issue : 04/2021

The following section covers the spare parts diagrams and lists that were current at the time this manual was originally printed. Due to continuous improvements of the machine, changes may be made at any time without notification.

HOW TO ORDER SPARE PARTS

1. Have your machines **model number, serial number & date of manufacture** on hand, these can be found on the specification plate mounted on the machine
2. A scanned copy of your parts list/diagram with required spare part/s identified
3. Go to www.machineryhouse.com.au/contactus and fill out the inquiry form attaching a copy of scanned parts list.

CONTENTS

Spare Parts Diagram.....	24
Spare Parts List.....	25
Wiring Diagram.....	27
Wiring Spare Parts List.....	22

SPARE PARTS DIAGRAM

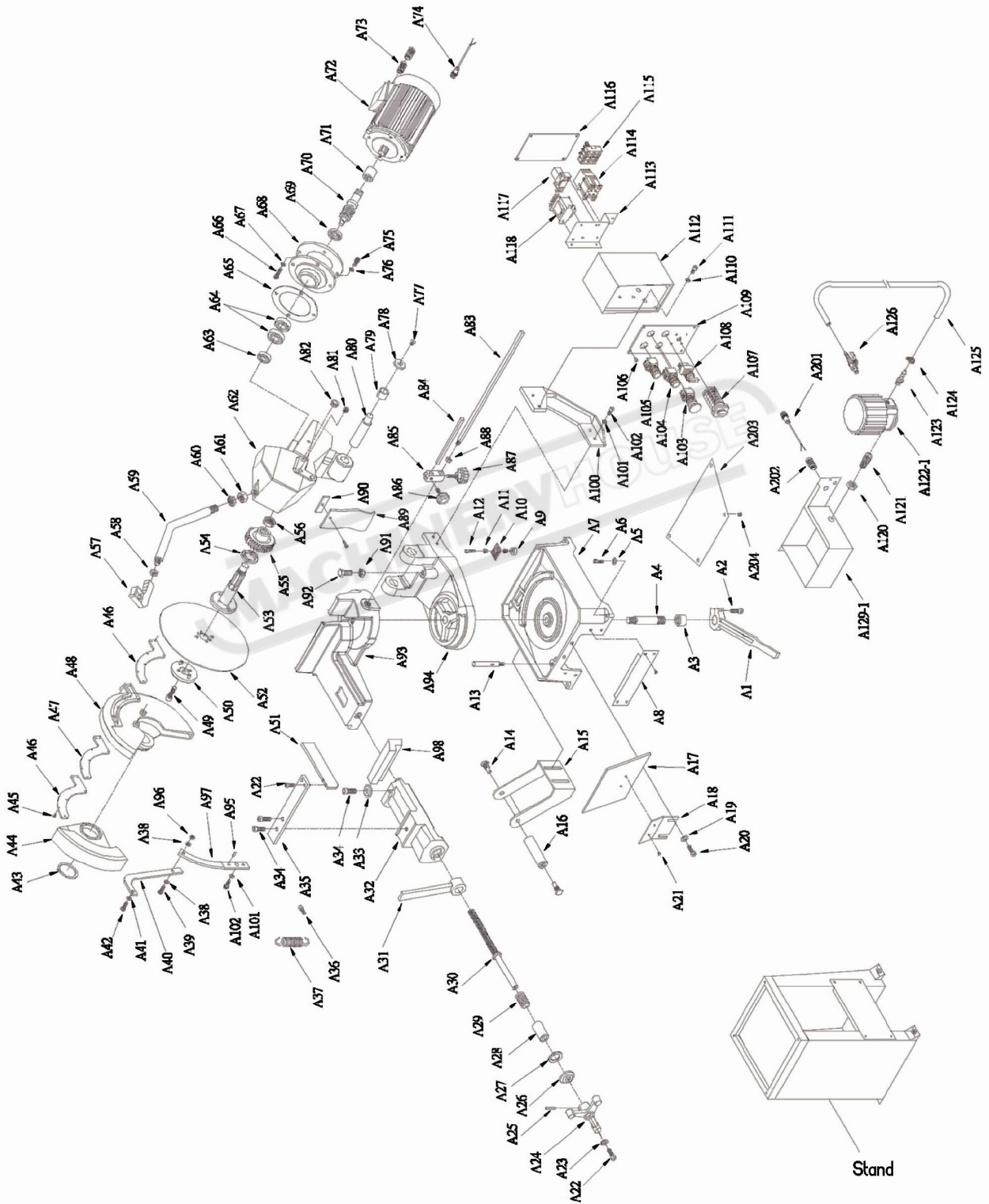

OPERATION MANUAL

SPARE PARTS LIST

ITEM	DESCRIPTION	SIZE	QTY	ITEM	DESCRIPTION	SIZE	QTY
A1	LOCK HANDLE		1	A41	WASHER	1/4"	1
A2	HEX SOCKET CAP SCREW	M10X30	1	A42	HEX SOCKET CAP SCREW	M6X12	1
A3	LOCK NUT		1	A43	C-CLIP	S60	1
A4	SHAFT		1	A44	BLADE SHIELD		1
A5	SPRING WASHER	5/16"	4	A45	SCREW	M5X10	7
A6	HEX SOCKET CAP SCREW	M8X35	4	A46	PLATE		2
A7	MACHINE BASE		1	A47	RUBBER SHEET		2
A8	PLATE		1	A48	BLADE COVER		1
A9	COUNTER WEIGHT		1	A49	HEX SOCKET CAP SCREW	M12X35	1
A10	FILTER NET		1	A50	FIXING FLANGE		1
A11	NUT		2	A51	STOPPER		1
A12	HEX SOCKET CAP SCREW	M8X25	1	A52	SAW BLADE		1
A13	SUPPORT ROD		1	A53	SPINDLE SHAFT		1
A14	ROLLER SHAFT		2	A54	OIL SEAL	35X47X8	1
A15	ROLLER BRACKET		1	A55	WORM GEAR		1
A16	ROLLER		1	A56	LOCK NUT		1
A17	PLATE		1	A57	TRIGGER SWITCH WITH HANDLE		1
A18	PLATE		1	A58	NUT	M10	1
A19	WASHER	5/16"	2	A59	CONTROL HANDLE ROD		1
A20	HEX SOCKET CAP SCREW	M8X16	2	A60	NUT	M20	1
A21	SCREW	M5	2	A61	NUT	M20	1
A22	HEX SOCKET CAP SCREW	M8X20	3	A62	MACHINE HEAD		1
A23	WASHER	5/16"	1	A63	BALL BEARING	6205ZZ	1
A24	HANDLE WHEEL		1	A64	BALL BEARING	6301ZZ	2
A25	PIN	5X40	1	A65	RUBBER SHEET		1
A26	BEARING COVER		1	A66	HEX CAP SCREW	M8X20	4
A27	THRUST BEARING		1	A67	WASHER	5/16"	4
A28	BUSHING		1	A68	FLANGE		1
A29	SPRING		1	A69	OIL SEAL	25X45X10	1
A30	LEADING SCREW		1	A70	WORM SHAFT		1
A31	LOCK HANDLE		1	A71	COUPLING		1
A32	SLIDING VISE		1	A72	MOTOR 1HP		1
A33	WASHER		1	A73	WIRE TERMINAL CLAMP		2
A34	HEX SOCKET CAP SCREW		2	A74	CONTROL WIRE		1
A35	PLATE		1	A75	HEX CAP SCREW	M8X20	4
A36	SCREW	M10X30	1	A76	WASHER	5/16"	4
A37	SPRING		1	A77	SCREW	M8	2
A38	WASHER	1/4"	2	A78	COVER		2
A39	HEX SOCKET CAP SCREW	M6X25	1	A79	BUSHING		1
A40	SWITCHING HANDLE		1	A80	SHAFT		1

NOTE: SOME INDIVIDUAL PARTS MAY ONLY BE AVAILABLE AS AN ASSEMBLY

SPARE PARTS LIST

ITEM	DESCRIPTION	SIZE	QTY	ITEM	DESCRIPTION	SIZE	QTY
A81	SET SCREW	PT1/4"	2	A123	CONNECTING BOLT		1
A82	OIL PILOT	20M/M	1	A124	HOSE CLAMP		2
A83	LOWER LENGTH SETTING ROD		1	A125	HOSE		1
A84	UPPER LENGTH SETTING ROD		1	A126	VALVE		1
A85	LENGTH SETTING RODS HOLDER		1	A129-1	COOLANT TANK		1
A86	LOCK BOLT WITH KNOB		1	A201	CONTROL WIRE		1
A87	LOCK BOLT WITH KNOB		1	A202	WIRE TERMINAL CLAMP		1
A88	NUT	M12	1	A203	SUPPORT PLATE		1
A89	ANTI-DUST PLATE		1	A204	HEX. CAP SCREW	M6X10	4
A90	HOLDER PLATE		1				
A91	NUT	M12	1				
A92	HEX CAP SCREW		1				
A93	WISE BENCH		1				
A94	SWING ARM (BASE)		1				
A95	PIN	5X14	2				
A96	NUT	M6	1				
A97	SWITCHING SUPPORTER		1				
A98	WISE CLAMP		1				
A100	SUPPORTER		1				
A101	WASHER	5/16"	2				
A102	HEX SOCKET CAP SCREW	M8X20	2				
A103	EMERGENCY SWITCH		1				
A104	START BUTTON		1				
A105	STOP BUTTON		1				
A106	SCREW	M5	4				
A107	SELECT SWITCH		1				
A108	PUMP SELECTION SWITCH		1				
A109	CONTROL PANEL		1				
A110	WASHER	5/16"	2				
A111	HEX SOCKET CAP SCREW	M8X20	2				
A112	ELECTRIC CONTROL BOX		1				
A113	CONTROL BOX BOTTOM PLATE		1				
A114	MAGNETIC CONTACTOR		1				
A115	FUSE SET		1				
A116	COVER PLATE		1				
A117	RELAY		1				
A118	TRANSFORMER		1				
A120	NUT	M20X1.5	1				
A121	PT SCREW		1				
A122-1	COOLANT PUMP		1				

NOTE: SOME INDIVIDUAL PARTS MAY ONLY BE AVAILABLE AS AN ASSEMBLY

WIRING DIAGRAM

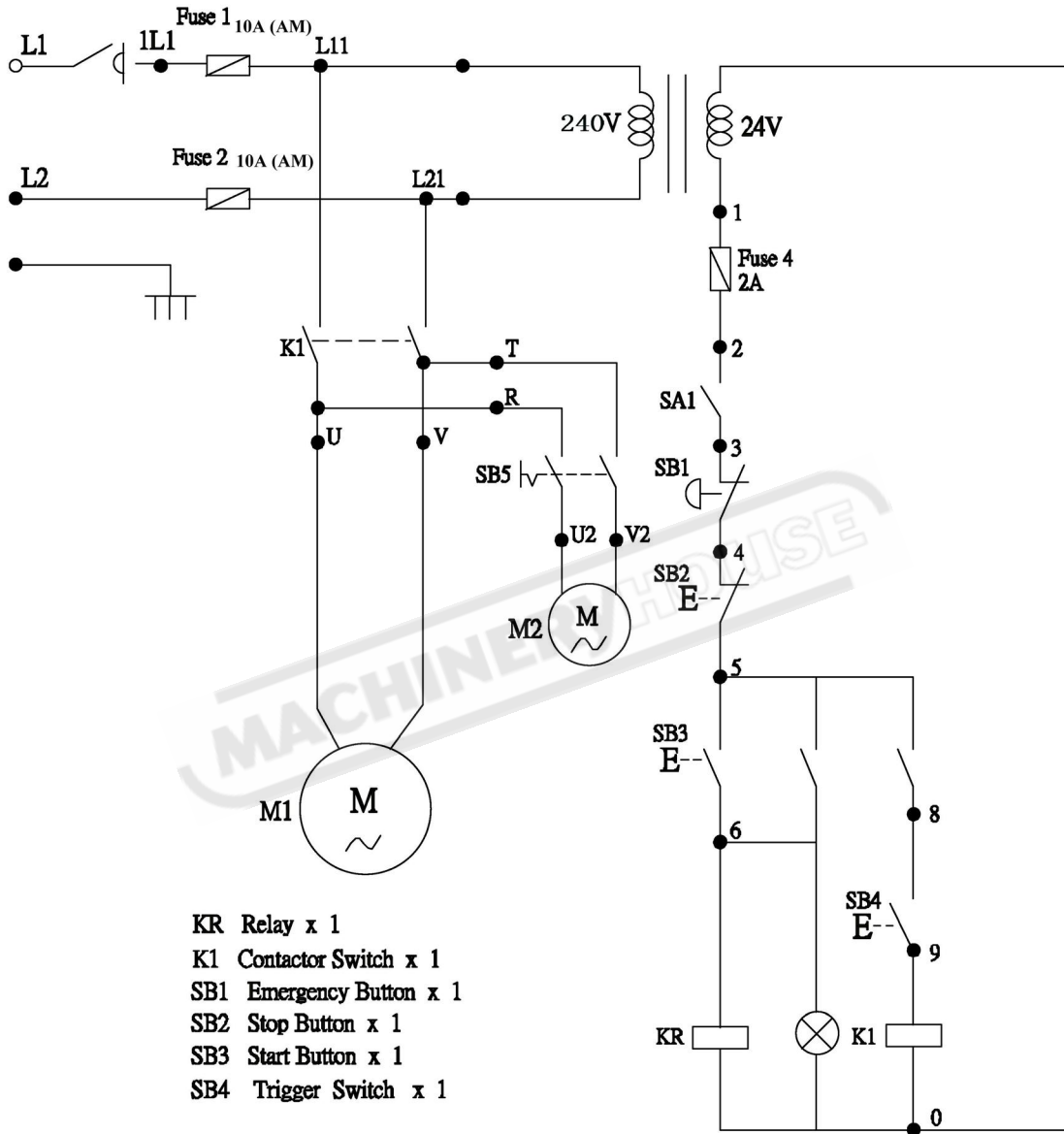

WIRING SPARE PARTS LIST.

Item name	Description and function	Technical data	Quantity	Supplier	Suppliers reference	Remarks
FU1 FU2 FU3	Fuses	10A(T) 10A(T) 2A	1 1 1	JENN FENG	S15A	
	Fuses base	10A 3P	1		FSB-104	CE
K1	Contactors	Coil 24V I _e =25A 220V 2.2kw 400V 4.0kw	1	NHD	C-09D	ICE 158-1 BS 5424-1 VDE 0660 J13 8325
KR	Relay	250VAC 5A	1	SHINOHAWA	MY-2N AC 24V	CE CSA
TC	Transformer	35VA 400/24V	1	JIA LIXIN	57	
SB1	Emergency Stop	250V 6A	1	KEDU	HY57B	CE CUS
SB2 SB3	OFF button Start button	250V 6A	1 1	MAACK	ABF-22Φ 1b ABLFS-22Φ 1a 30V	CE CUS
SB4	Trigger switch	15A 1/2HP 125 250VAC 0.6A 125VDC 0.3A 250VDC	1	OMRON	V-15-1A5	CE CUS
SB5	Pump switch	250V	1	GIKOKA	OSS-22Φ	CE CUS
SA1	Hi/Low speed select switch	440V 5kw	1	KEDU	ZH-HC-5	CE CUS
M1	Motor	220V~240V/ 0.75kw (1HP) 1ph/4P	1	KAI SHEN		
M2	Coolant pump	220~240V / 1ph 0.09kw (1/8HP)	1	KAI SHEN		

WARNING

General Machinery Safety Instructions

Machinery House
requires you to read this entire Manual before using this machine.

- 1. Read the entire Manual before starting machinery.** Machinery may cause serious injury if not correctly used.
- 2. Always use correct hearing protection when operating machinery.** Machinery noise may cause permanent hearing damage.
- 3. Machinery must never be used when tired, or under the influence of drugs or alcohol.** When running machinery you must be alert at all times.
- 4. Wear correct Clothing.** At all times remove all loose clothing, necklaces, rings, jewelry, etc. Long hair must be contained in a hair net. Non-slip protective footwear must be worn.
- 5. Always wear correct respirators around fumes or dust when operating machinery.** Machinery fumes & dust can cause serious respiratory illness. Dust extractors must be used where applicable.
- 6. Always wear correct safety glasses.** When machining you must use the correct eye protection to prevent injuring your eyes.
- 7. Keep work clean and make sure you have good lighting.** Cluttered and dark shadows may cause accidents.
- 8. Personnel must be properly trained or well supervised when operating machinery.** Make sure you have clear and safe understanding of the machine you are operating.
- 9. Keep children and visitors away.** Make sure children and visitors are at a safe distance for you work area.
- 10. Keep your workshop childproof.** Use padlocks, Turn off master power switches and remove start switch keys.
- 11. Never leave machine unattended.** Turn power off and wait till machine has come to a complete stop before leaving the machine unattended.
- 12. Make a safe working environment.** Do not use machine in a damp, wet area, or where flammable or noxious fumes may exist.
- 13. Disconnect main power before service machine.** Make sure power switch is in the off position before re-connecting.
- 14. Use correct amperage extension cords.** Undersized extension cords overheat and lose power. Replace extension cords if they become damaged.
- 15. Keep machine well maintained.** Keep blades sharp and clean for best and safest performance. Follow instructions when lubricating and changing accessories.
- 16. Keep machine well guarded.** Make sure guards on machine are in place and are all working correctly.
- 17. Do not overreach.** Keep proper footing and balance at all times.
- 18. Secure workpiece.** Use clamps or a vice to hold the workpiece where practical. Keeping the workpiece secure will free up your hand to operate the machine and will protect hand from injury.
- 19. Check machine over before operating.** Check machine for damaged parts, loose bolts, Keys and wrenches left on machine and any other conditions that may effect the machines operation. Repair and replace damaged parts.
- 20. Use recommended accessories.** Refer to instruction manual or ask correct service officer when using accessories. The use of improper accessories may cause the risk of injury.
- 21. Do not force machinery.** Work at the speed and capacity at which the machine or accessory was designed.
- 22. Use correct lifting practice.** Always use the correct lifting methods when using machinery. Incorrect lifting methods can cause serious injury.
- 23. Lock mobile bases.** Make sure any mobile bases are locked before using machine.
- 24. Allergic reactions.** Certain metal shavings and cutting fluids may cause an allergic reaction in people and animals, especially when cutting as the fumes can be inhaled. Make sure you know what type of metal and cutting fluid you will be exposed to and how to avoid contamination.
- 25. Call for help.** If at any time you experience difficulties, stop the machine and call you nearest branch service department for help.

WARNING

Metal Cutting Coldsaw Safety Instructions

Machinery House
requires you to read this entire Manual before using this machine.

- 1. Maintenance.** Make sure the saw is turned off and disconnect from the main power supply and make sure all moving parts have come to a complete stop before any inspection, adjustment or maintenance is carried out.
- 2. Saw Condition.** Saw must be maintained for a proper working condition. Never operate a saw that has damaged or worn parts. Scheduled routine maintenance should be performed on a scheduled basis.
- 3. Blade Condition.** Never operate a saw with a dull, cracked or badly worn blade. Before using a saw inspect blades for missing teeth and cracks.
- 4. Replacing Blade.** Make sure teeth are facing the correct direction. Wear gloves to protect hands.
- 5. Hand Hazard.** Keep hands and fingers clear from the line of cut of the blade and offcuts workpieces. Hands can be crushed in vice or from falling machine components and cut by the blade.
- 6. Leaving a saw Unattended.** Always turn the saw off and make sure all moving parts have come to a complete stop before leaving the saw. Do not leave saw running unattended for any reason.
- 7. Avoiding Entanglement.** Blade guard must be used at all times. Remove loose clothing, belts, or jewelry items. Never wear gloves while machine is in operation. Tie up long hair and use the correct hair nets to avoid any entanglement with the saw moving parts.
- 8. Understand the machines controls.** Make sure you understand the use and operation of all controls.
- 9. Power outage.** In the event of a power failure during use of the saw, turn off all switches to avoid possible sudden start up once power is restored.
- 10. Work area hazards.** Keep the area around the saw clean from oil, tools, chips. Pay attention to other persons in the area and know what is going on around the area to ensure unintended accidents.
- 11. Workpiece Handling.** Workpieces must be supported with table, vice, roller conveyor/stands, or other support fixtures. Unsupported workpieces may cause the machine to tip over and fall. Flag long pieces of material to avoid tripping hazards. Never hold a workpiece with your hands during the cut process.
- 12. Hearing protection and hazards.** Always wear hearing protection as noise generated from saw blade and workpiece vibration, material handling, and power transmission can cause permanent hearing loss over time.
- 13. Hot surfaces.** Workpieces, machine surfaces and chips become hot due to friction and can burn you.
- 14. Starting position.** Never turn the saw on when the blade is resting on the workpiece.
- 15. Guards.** Do not operate saw without the blade guard in place. Ensure all guards removed to do maintenance or change blades on the machine are refitted correctly in place before the machine is used again.
- 16. Call for help.** If at any time you experience difficulties, stop the machine and call your nearest branch service department for help.

PLANT SAFETY PROGRAM

NEW MACHINERY HAZARD IDENTIFICATION, ASSESSMENT & CONTROL

Metal Cutting Coldsaw

Developed in Co-operation Between A.W.I.S.A and Australia Chamber of Manufactures
This program is based upon the Safe Work Australia, Code of Practice - Managing Risks of Plant in the Workplace (WHSA 2011 No10)

Item No.	Hazard Identification	Hazard Assessment	Risk Control Strategies <small>(Recommended for Purchase / Buyer / User)</small>
A	ENTANGLEMENT	HIGH	Eliminate, avoid loose clothing / Long hair etc.
B	CRUSHING	LOW	Secure & support Long / heavy material
C	CUTTING, STABBING, PUNCTURING	MEDIUM	Isolate main power switch before changing blade, cleaning or adjusting. Check blade is tight and in good condition before starting. Make sure blade guard is down in correct position when machine is on.
D	SHEARING	MEDIUM	Make sure all guards are secured shut when machine is on. Isolate power to machine prior to any checks or maintenance.
F	STRIKING	LOW	Support long heavy jobs and stand clear of offcuts falling. Remove all loose objects around moving parts. Wear safety glasses.
H	ELECTRICAL	MEDIUM	All electrical enclosures should only be opened with a tool that is not to be kept with the machine.
O	OTHER HAZARDS, NOISE.	LOW	Machine should be installed & checked by a Licensed Electrician. Wear hearing protection as required.
Plant Safety Program to be read in conjunction with manufactures instructions			



www.machineryhouse.com.au



www.machineryhouse.co.nz

Authorised and signed by:
Safety officer:



Manager:



Revised Date: 12th March 2012